

Meow Mix[®]

Purfect Pies Package
and
Packaging Design

8 Week Project



2018 Smucker's
Cat Food

DESIGN STUDIO

RESEARCH

PET OWNERSHIP IN THE US



WHAT CONSUMERS WANT:



1/4 BETTER NUTRITIONAL VALUE



1/3 PORTION CONTROL

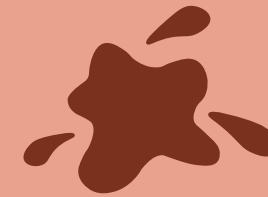

1/2 MESS FREE

GOAL: HELP PORTION CONTROL AND DECREASE MESS



SKETCHES

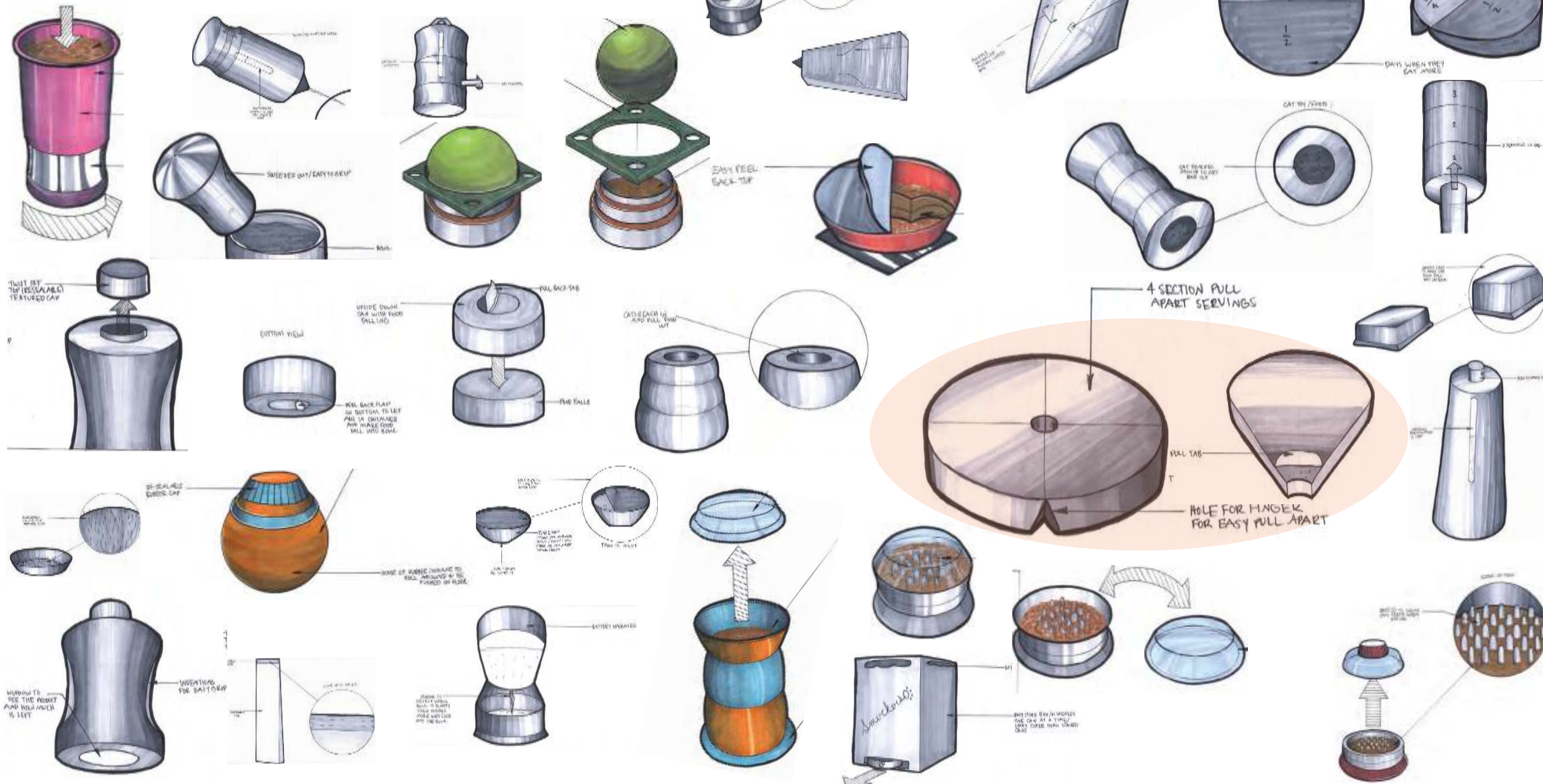

PROTOTYPING

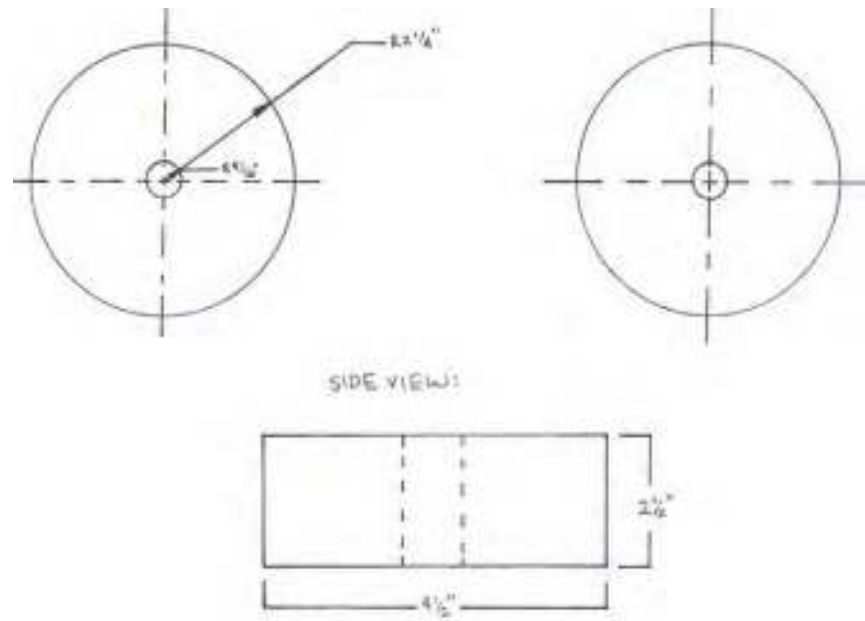

SEQUENCE OF USE

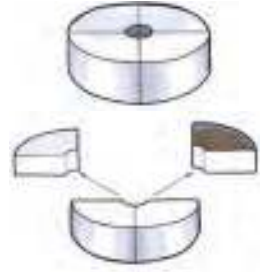

1. Tear off desired number of servings



2. Peel back tab to expose the cat food

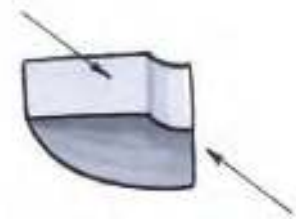

3. Squeeze edges to release cat food into dish





Meow
Mix